

Purchase Agreement

09/01/2017



To:
 HILL CITY SCHOOL
 ROXANN DUBOIS
 440 MAIN STREET
 HILL CITY, SD 57745-
 (605)574-3012

Project:
 FOOD SERVICE EQUIPMENT ITEMS
 FOR HILL CITY SCHOOLS

From:
 Cash-Wa Distributing - Aberdeen
 Keith Schumacher
 810 3rd Avenue S.E.
 Aberdeen, SD 57401-4608
 6052251275 5543
 (605)225-1275 5543 (Contact)

PRICES ARE GOOD FOR 30 DAYS. PRICES ARE DELIVERED TO YOUR LOCATION. PRICES DO NOT INCLUDE ANY INSTALLATION COSTS. PLEASE ALLOW 2 WEEKS FOR DELIVERY AFTER RECEIPT OF ORDERE. ANY QUESTIONS PLEASE CALL US AT 800-888-2617 EXT:5543 OR E-MAIL ME

| Item | Qty | Description | Sell | Sell Total |
|------|------|---|--------------------|-------------------|
| 1 | 1 ea | CONVECTION OVEN, ELECTRIC Vulcan Model No. VC55ED Convection Oven, electric, double-deck, standard depth, solid state controls, 5-hour timer with digital display enhancement, 150° to 500°F temperature range, (5) oven racks per deck, independently operated removable doors with double pane windows, porcelain on steel interior, interior light, stainless steel front, top, & sides, 8" stainless steel legs, (2) 1/2 HP blower motors, 25.0 kW, NSF, UL Listed, ENERGY STAR® | \$8,279.45 | \$8,279.45 |
| | 1 ea | 1 year limited parts & labor warranty, standard | | |
| | 1 ea | K-12 School Nutrition extended warranty extends the warranty for 12 months beyond the 12 month Original Equipment Warranty, not to exceed 24 months from date of installation | | |
| | 1 ea | (2) 208v/60/3-ph, standard | | |
| | 1 st | Casters, set of (4) in lieu of standard legs | \$70.00 | \$70.00 |
| | | | ITEM TOTAL: | \$8,349.45 |
| 2 | 1 ea | CONVECTION STEAMER, ELECTRIC Vulcan Model No. C24EA10 Convection Steamer, Electric, 2 compartments, 24" cabinet base, (10)12" x 20" x 2-1/2" deep total pan capacity, high output stainless steel steam generator with Timed Smart Drain & Powerflush Drain, manual control with 60-minute timer with buzzer each compartment, staged fill, split water line, single drain connection, stainless steel | \$13,486.66 | \$13,486.66 |

| Item | Qty | Description | Sell | Sell Total |
|------|------|---|--------------------|--------------------|
| | | interior, exterior, frame & flanged feet | | |
| | 1 ea | 1 year limited parts & labor warranty, standard | | |
| | 1 ea | K-12 School Nutrition extended warranty extends the warranty for 12 months beyond the 12 month Original Equipment Warranty, not to exceed 24 months from date of installation | | |
| | 1 ea | BSC controls: Basic control package, manual control with 60-minute timer, manual drain with timed SmartDrain and PowerFlush System, standard | | |
| | 1 ea | 208v/50/60/3-ph, 67.0 amps, 24.0kW, direct wire, standard | | |
| | 1 ea | SMF620 SYSTEM SCALEBLOCKER™ Water Treatment, field installed by others at job site | \$796.49 | \$796.49 |
| | 1 ea | 2nd year limited water related parts only & labor warranty, standard | | |
| | | | ITEM TOTAL: | \$14,283.15 |
| 3 | 1 ea | TILTING SKILLET BRAISING PAN, ELECTRIC | \$12,517.18 | \$12,517.18 |
| | | Vulcan Model No. VE40 | | |
| | | Braising Pan, electric, 40-gallon capacity, 46" wide open base, manual tilt, 9" deep stainless steel pan with gallon markings, pouring lip & removable strainer, spring assist cover with drip edge, pan holder, water tight solid state controls, includes L faucet bracket, 12" stainless steel legs with adjustable flanged feet, UL, cUL, UL EPH | | |
| | 1 ea | 1 year limited parts & labor warranty, standard | | |
| | 1 ea | K-12 School Nutrition extended warranty extends the warranty for 12 months beyond the 12 month Original Equipment Warranty, not to exceed 24 months from date of installation | | |
| | 1 ea | 208v/60/1-ph, 12 kW, 58 amps, direct wire | | |
| | 1 ea | SGLTS 18NZLJ SINGLE Pantry Deck Mount Faucet, 18" double jointed swivel spout, includes 4" and 12" riser, NSF and Lead Reduction Compliant | \$248.38 | \$248.38 |
| | 1 ea | Motor driven pan lift | \$840.71 | \$840.71 |
| | | | ITEM TOTAL: | \$13,606.27 |
| 4 | 1 ea | PASS-THRU MOBILE HEATED CABINET | \$3,916.49 | \$3,916.49 |
| | | Vulcan Model No. VPT13 | | |
| | | Holding/Transport Cabinet, Pass-thru, Mobile, capacity (13) 18" x 26" x 1" or (26) 12" x 20" x 2-1/2" pans, forced air blower, side mounted push handles, recessed control panel, analog thermometer ambient to 190° F, includes (10) pair of universal tray slides adjustable 1-1/2" OC, 20 gauge stainless steel interior and exterior, 5" casters, cULus, UL EPH, ENERGY STAR® | | |
| | 1 ea | 1 year limited parts & labor warranty, standard | | |
| | 1 ea | Lifetime warranty on heating elements, standard | | |
| | 1 ea | K-12 School Nutrition extended warranty extends the warranty for 12 months beyond the 12 month Original Equipment Warranty, not to exceed 24 months from date of installation | | |
| | 1 ea | 120v/50-60/1-ph, 1500 watts, 12.5 amps, 8' cord, NEMA 5-15P, standard | | |
| | 1 ea | Front door(s) hinged right side, rear hinged right, standard | | |
| | 1 ea | Full perimeter bumper | \$178.74 | \$178.74 |
| | 1 ea | 5" Casters, set of (4) standard | | |
| | 1 ea | NOTE -- IF CABINET IS ORDERED WITH OTHER VULCAN UNIT IT WILL | | |



| Item | Qty | Description | Sell | Sell Total |
|------|------|---|--------------------|--------------------|
| | | SHIP "FREIGHT FREE" IF UNIT IS ORDERED BY ITSELF -- FRT. CHARGE WILL BE: 203.16 | | |
| | | | ITEM TOTAL: | \$4,095.23 |
| 5 | 1 ea | PROOFER CABINET, MOBILE Vulcan Model No. VP18 Proofing Heated Cabinet, mobile, non-insulated, (18) 18" x 26" x 1" sheet pans or (36) 12" x 20" x 2-1/2" steam table pans, fan & air tunnel, includes (10) pair of adjustable tray slides 3" OC, 1/2 gallon water pan, switch can be set to proof or set for heated holding up to 190° F, glass door, stainless steel construction, includes drip trough & removable drip pan, 5" casters; 2 swivel, 2 rigid with locks, 120v/50/60/1-ph, 2.0 kW, 8' cord, NEMA 5-20P | \$2,188.32 | \$2,188.32 |
| | 1 ea | 1 year limited parts & labor warranty, standard | | |
| | 1 ea | Lifetime warranty on heating elements, standard | | |
| | 1 ea | K-12 School Nutrition extended warranty extends the warranty for 12 months beyond the 12 month Original Equipment Warranty, not to exceed 24 months from date of installation | | |
| | 1 ea | NOTE: IF THIS CABINET SHIPS WITH OTHER VULCAN ITEMS - IT WIL;L SHIP "FREIGHT FREE" IF ORDER SEPERATELY -- ADD 203.16 FRT. CHARGE | | |
| | | | ITEM TOTAL: | \$2,188.32 |
| | | | Total | \$42,522.42 |

All material is guaranteed to be specified and the above work to be performed in accordance with the drawings and specifications submitted for above work and completed in a substantial workmanlike manner for the sum of Dollars(\$ _____).

_____ CWD requires a 30% deposit on all special order equipment before the order is placed.
 _____ CWD requires a 50% deposit on all custom special order equipment before the order is placed.

Direct Ship Items: Please note it is the responsibility of the customer to file all freight claims directly with the freight company. CWD will not file any direct shipment claims with the freight companies on direct shipments. Please check all items thoroughly at time of delivery and address any issues with the carrier at the time of delivery. We strongly suggest that on direct shipments that boxes are opened and inspected thoroughly at time of delivery before transporter leaves the job site as concealed damage also needs to be reported directly to shipper. All freight companies have a window of time to report concealed damage otherwise they are not responsible and either is CWD.

CWD Distributing payment terms for all special or custom order equipment is 7 days from date of invoice.

CWD will file a UCC1 form with the state on all equipment purchased over \$1500.00

_____ If this proposal is for an Exhaust System, the customer must meet all NFPA 96 Exhaust Hood Codes and/or all Local and State Codes approved by Local Fire Marshall. If not all Codes are met, CWD will not install any of the foodservice equipment that is to be located under this exhaust system.

Any alterations or deviation from above specifications involving extra costs will be executed upon written orders and will become an extra charge over and above the estimate. This agreements is contingent upon strikes, accidents or any delays that are beyond our control. Owners to carry fire, tornado, and other necessary insurance upon above work. Workman's compensation and public liability insurance on

above work to be taken out by:

Respectfully

Submitted _____

Cash-Wa Distributing

ACCEPTANCE OF PROPOSAL- The above prices, specifications and conditions are satisfactory and are hereby accepted. You are authorized to do the work as specified. Payment will be made as outlined. The remainder of the payment is due within terms upon delivery.

Company: _____

Date: _____

Signature: _____

Per new 'NMFC' National Motor Freight Class guidelines, effective April 18, 2015, concealed damages must be reported to carriers within 5 days after delivery.

Currently, concealed damages can be reported up to 15 days after delivery for consideration of a valid claim, but per NMFC guidelines effective April 18, 2015, the time period for reporting concealed damages is being reduced 5 days. I have attached a document with all changes being implemented by the NMFC effective April 18, and below is a summation of the concealed damage rule change.

As you probably know, this is not a ReTrans policy/rule, rather a change being enacted by the NMFC. Should you have any questions, please feel free to reach out to me.

Supplement 1 to NMF 100-AO, effective April 18, 2015

ITEM 300135-A REPORTING CONCEALED DAMAGE

(a) When damage to, or loss of, contents of a shipping container is discovered by the consignee that could not have been determined at time of delivery it must be reported by the consignee to the delivering carrier upon discovery. (b) Reports must include a request for inspection by the carrier's representative. (c) Notice of loss or damage and request for inspection may be given by telephone or in person, but in either event must be confirmed by a written or electronic communication. (d) While awaiting inspection by carrier, the consignee must hold the shipping container and its contents in the same condition they were in when damage was discovered, insofar as it is possible to do so. (e) **Unless otherwise specified by the carrier, notice of loss or damage should be provided to the carrier within five (5) business days from the date of delivery.** (f) If five (5) business days, or such other period as specified by the carrier, pass between the date of delivery of the shipment by carrier and date of report of loss or damage and request for inspection by consignee, it is incumbent upon the consignee to offer reasonable evidence to the carrier's representative when inspection is made that loss or damage was not incurred by the consignee after delivery of shipment by carrier.

SUPPLEMENT 1 TO NMF 100-AO PROCEDURES GOVERNING THE INVESTIGATION AND DISPOSITION OF FREIGHT CLAIMS FOR LOSS OR DAMAGE

Only participants in the NMFC® at the time the transportation occurs may use the provisions herein. 14 For explanation of abbreviations and reference marks, see last page of this Supplement. ©NMFTA 2015 ITEM 300135-A-Continued (g) Reasonable evidence includes, but is not limited to: 1. Identifying the party(ies) responsible for unloading, 2. Identifying the chain of custody of the article, including prior transportation by any mode, 3. Location(s) of the article(s) once the shipment was received until the

damage was noted, 4. Any mechanical or physical handling by the consignee subsequent to delivery by the carrier. (h) If a clear delivery receipt is available on the shipment, e.g. no damage or shortage is noted, the claimant must provide documentation showing that damage or loss occurred prior to delivery

CWD

Keith Schumacher

keith.schumacher@cashwa.com

Acceptance: _____ Date: _____

Printed Name: _____

Project Grand Total: \$42,522.42

OVENS

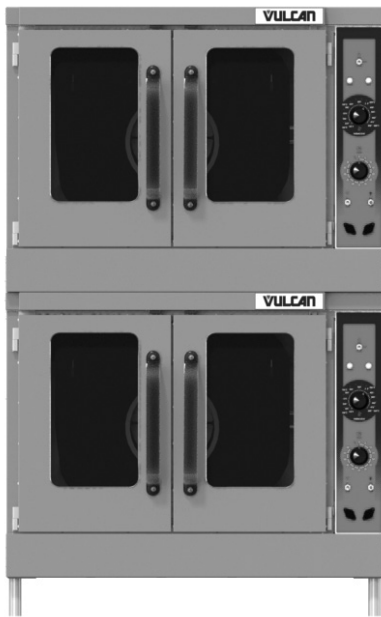
VULCAN**VC55E SERIES
DOUBLE DECK ELECTRIC CONVECTION OVENS**

Model VC55ED
Shown with optional legs

**SPECIFICATIONS**

Double section, electric convection oven, Vulcan Model No. (VC55ED). Stainless steel front, sides, top and legs. Independently operated stainless steel doors with double pane windows. Non-sag insulation applied to the top, rear, sides, bottom and doors. Porcelain enamel on steel oven interiors measure 29"w x 22 $\frac{1}{8}$ "d x 20"h. One interior oven lights per section. Five nickel plated oven racks per section measure 28 $\frac{1}{4}$ " x 20 $\frac{1}{2}$ ". Eleven position nickel plated rack guides with positive rack stops per section. Each section heated by electric solid sheath elements rated at 12 KW. Furnished with a two speed $\frac{1}{2}$ H.P. oven blower-motor per section. Oven cool switch for rapid cool down. 208 or 240 volt, 60 Hz, 1 or 3 phase.

Exterior Dimensions:

40.1"w x 40.0"d (includes motor & door handles) 37.75"d (includes motor only) x 70"h on 8" legs.

NSF listed. UL listed.

- VC55ED** Solid state temperature dial controls adjust from 150° to 500°F with digital display enhancement. 5-hour timer with audible alarm.

STANDARD FEATURES

- Independently operated removable stainless steel doors with double pane windows.
- Gentle Bake mode selector switch.
- On-board diagnostics for easy servicing
- Five nickel plated grab-and-go oven racks with eleven rack positions per section.
- Stainless steel front, sides, top and legs.
- 25 total KW.
- $\frac{1}{2}$ H.P. two speed oven blower-motor.
- Moisture vent.
- Oven cool switch for rapid cool down.
- Porcelain enamel on steel oven interiors.
- One year limited parts and labor warranty.

OPTIONS

- Casters.
- 480V/60 Hz/1 or 3 phase.
- Second year extended limited parts and labor warranty.

ACCESSORIES

- Stainless steel rear motor enclosure.
- Extra oven rack(s).
- Rack hanger(s).
- Stainless steel drip pan.
- Down draft flue diverter for direct vent connection.

VULCAN

a division of ITW Food Equipment Group LLC

P.O. Box 696 ■ Louisville, KY 40201 ■ Toll-free: 1-800-814-2028 ■ Local: 502-778-2791 ■ Quote & Order Fax: 1-800-444-0602

O V E N S



VC55E SERIES
DOUBLE DECK ELECTRIC CONVECTION OVENS

OPTIONAL VOLTAGES

480 volt, 60 Hz, 3 phase.

CLEARANCES

| | Combustible | Non-Combustible |
|------------|-------------|-----------------|
| Rear | 2" | 2" |
| Right Side | 4" | 4" |
| Left Side | 1" | 1" |

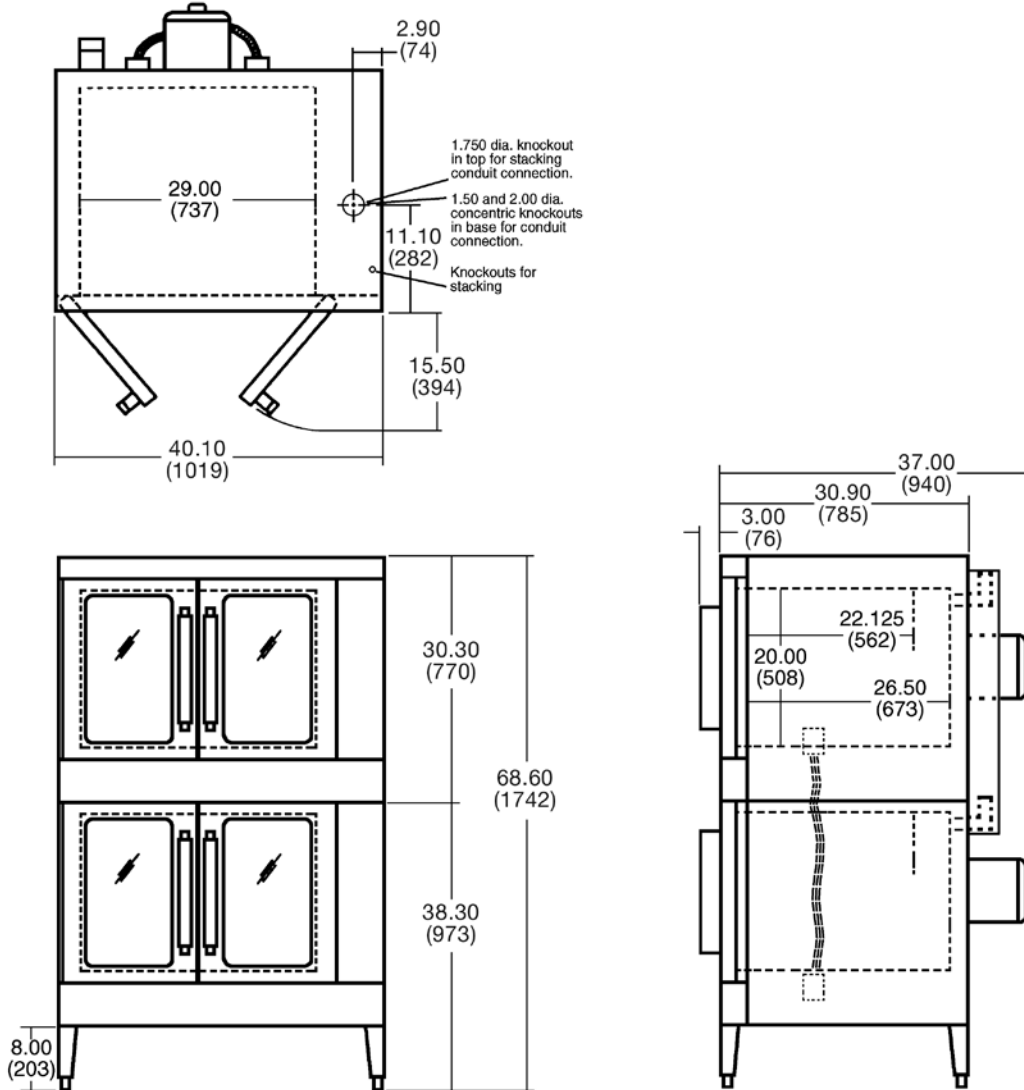

| MODEL NO. | TOTAL CONN. KW | 3 PHASE LOAD KW PER PHASE | | NOMINAL AMPS PER LINE WIRE | | | | | | | | | | | | WEIGHT | | | | | |
|-----------|----------------|---------------------------|---|----------------------------|-----|-----|----------|----|----|----------|----|----|----|-----|-----|---------|------|------------------------|-----|---------------------------|----|
| | | | | 3 PHASE | | | | | | | | | | | | 1 PHASE | | WITH SKIDS & PACKAGING | | WITHOUT SKIDS & PACKAGING | |
| | | | | 208 VOLT | | | 240 VOLT | | | 480 VOLT | | | | | | | | | | | |
| | | | | X-Y | Y-Z | X-Z | X | Y | Z | X | Y | Z | X | Y | Z | 208V | 240V | LBS. | KG | LBS. | KG |
| VC55E | 25 | 8 | 8 | 9 | 70 | 66 | 70 | 66 | 58 | 66 | 28 | 30 | 30 | 120 | 104 | 674 | 306 | 572 | 260 | | |



a division of ITW Food Equipment Group LLC

P.O. Box 696 ■ Louisville, KY 40201 ■ Toll-free: 1-800-814-2028 ■ Local: 502-778-2791 ■ Quote & Order Fax: 1-800-444-0602

NOTE: In line with its policy to continually improve its products, Vulcan reserves the right to change materials and specifications without notice.

S T E A M

VULCAN**C24EA FLOOR SERIES
ELECTRIC CONVECTION STEAMER
ON CABINET BASE**

Model C24EA6



ANSI/NSF Standard #4

**SPECIFICATIONS**

Two compartment electric convection steamer on cabinet base, Vulcan-Hart Model No. (C24EA6-BSC) (C24EA10-BSC). Stainless steel exterior. Two stainless steel cooking compartments with coved interior corners. Stainless steel steam generator with staged water fill and Smart Drain System (timed drain) with PowerFlush. Separate 60 minute timer with constant steam feature for each compartment. Heavy duty doors and door latch mechanisms. Stainless steel water resistant cabinet base with stainless steel enclosed bottom. 6" adjustable stainless steel legs with flanged feet. Shipped for 208/60-50/3 electrical service. Can be field converted to 208/60-50/1 and 240/60-50/3 and 240/60-50/1. Split water line connection. Treated and untreated water connections. 1½" NPT drain connection.

Exterior Dimensions:

6 pan: 24"w x 35.4"d x 58.5"h on 6" legs.

10 pan: 24"w x 35.4"d x 67.9"h on 6" legs.

UL listed. Classified by UL to NSF Std. #4.

- C24EA6-BSC 6 pan capacity basic controls
- C24EA6-DLX 6 pan capacity professional controls
- C24EA10-BSC 10 pan capacity basic controls
- C24EA10-DLX 10 pan capacity professional controls

STANDARD FEATURES

- Stainless steel exterior.
- Two stainless steel cooking compartments with coved interior corners.
- Stainless steel steam generator with staged water fill, and Smart Drain System (timed drain) with PowerFlush.
- Separate 60 minute timer with constant steam feature for each compartment.
- Heavy duty doors and door latch mechanisms with gasket guard.
- Stainless steel water resistant cabinet base with enclosed bottom.
- 6" adjustable stainless steel legs with flanged feet.
- Shipped for 208/60-50/3 electrical service. Can be field converted to 208/60-50/1 and 240/60-50/3 and 240/60-50/1.
- Split water line connection. Treated and untreated water connections. 1½" NPT drain connection.
- One year limited parts and labor warranty.

OPTIONS

- Professional Control Package includes:
 - Superheated Steam System
- 480 volt, 50/60 Hz, 3 phase (Professional Control Package only).
- Steamer Security Package, includes controls protected by lockable cover, perforated flue cover, security fasteners & tack-welds.
- Second year extended limited parts and labor warranty contract.

ACCESSORIES (Packaged & Sold Separately)

- 12" x 20" stainless steel pans:
 - 1" deep (solid)(perforated) Qty. ____.
 - 2½" deep (solid)(perforated) Qty. ____.
 - 4" deep (solid)(perforated) Qty. ____.
- Stainless steel pan cover. Qty. ____.
- Removable sliding shelf. Qty. ____.
- Water treatment system.

VULCAN

a division of ITW Food Equipment Group LLC

P.O. Box 696 ■ Louisville, KY 40201 ■ Toll-free: 1-800-814-2028 ■ Local: 502-778-2791 ■ Quote & Order Fax: 1-800-444-0602

STEAM



C24EA FLOOR SERIES ELECTRIC CONVECTION STEAMER ON CABINET BASE

SERVICE CONNECTIONS:

ELECTRICAL CONNECTION: Single point supply 1 1/8" (29 mm) dia. (3/4" conduit).

DRAIN: Condenser box, compartment and generator, 1/2" NPT. (Provide an open air gap type drain within 12" of condenser box and for best results at a distance so steam vapors will not enter the steamer from underneath the control area. Do not connect solidly to any drain connection.)

GENERATOR WATER SUPPLY: 3/4" (19 mm) male NSHT to generator, cold water flow rate .5 gpm @ minimum 20 to maximum 60 psi. (138-414 kPa).

CONDENSING WATER SUPPLY: 3/4" (19 mm) male NSHT to condenser, cold water flow rate .5 gpm @ minimum 20 to maximum 60 psi. (138-414 kPa).

WATER QUALITY STATEMENT:

The fact that a water supply is potable is no guarantee that it is suitable for steam generation. Your water supply must be within these general guidelines:

| | |
|----------------------------|---------------------|
| SUPPLY PRESSURE | 20 - 60 psig |
| HARDNESS* | less than 3 grains |
| SILICA | less than 13 ppm |
| TOTAL CHLORIDE | less than 4.0 ppm |
| PH RANGE | 7-8 |
| UN-DISSOLVED SOLIDS | less than 5 microns |

* 17.1 ppm = 1 grain of hardness

Other factors affecting steam generation are iron content, amount of chloridation and dissolved gases. Water supplies vary from state to state and from locations within a state. Therefore it is necessary that the local water treatment specialist be consulted before the installation of any steam generating equipment.

NOTE:

- Dimensions which locate the above connections have a tolerance of + or -3" (+ or -75 mm). Normal dimensions are in inches. Dimensions in () are in millimeters.
- Installation of backflow preventers, vacuum breakers and other specific code requirements is the responsibility of the owner and installer. It is the responsibility of the owner and installer to comply with local codes.
- Do not use plastic drains.
- This appliance is manufactured for commercial installation only and is not intended for home use.

| COMPARTMENT PAN CAPACITY | | | | |
|--------------------------|----|--------|----|----|
| MODEL | 1" | 2 1/2" | 4" | 6" |
| C24EA6 | 6 | 3 | 2 | 1 |
| C24EA10 | 10 | 5 | 3 | 2 |

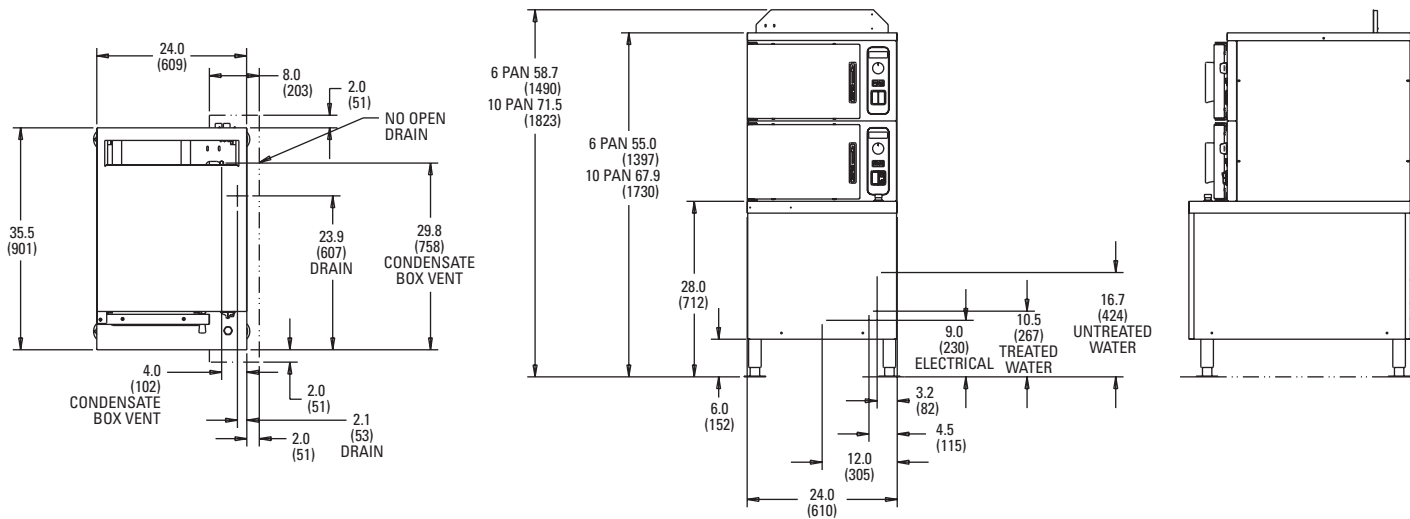

| BASIC CONTROL PACKAGE | | | | | | | |
|-----------------------|----|-------|-----|-------|-----|-------|-----|
| MODEL | PH | 208 V | | 240 V | | 480 V | |
| | | KW | AMP | KW | AMP | KW | AMP |
| C24EA6-BSC | 1 | 16.0 | 77 | 17.8 | 74 | N/A | N/A |
| | 3 | 16.0 | 44 | 17.8 | 51 | 16.0 | 19 |
| C24EA10-BSC | 1 | 24.0 | 115 | 24.9 | 104 | N/A | N/A |
| | 3 | 24.0 | 67 | 24.9 | 65 | 24.0 | 29 |

| PROFESSIONAL CONTROL PACKAGE | | | | | | | |
|------------------------------|----|-------|-----|-------|-----|-------|-----|
| MODEL | PH | 208 V | | 240 V | | 480 V | |
| | | KW | AMP | KW | AMP | KW | AMP |
| C24EA6-DLX | 1 | 16.9 | 81 | 19.0 | 79 | N/A | N/A |
| | 3 | 16.9 | 48 | 19.0 | 53 | 17.2 | 21 |
| C24EA10-DLX | 1 | 25.2 | 121 | 26.5 | 110 | N/A | N/A |
| | 3 | 25.2 | 72 | 26.5 | 67 | 25.6 | 32 |

NOTE: 3ø is an unbalanced load, and amps listed is the max on any leg. Refer to the Installation and Operation Manual for further details.



a division of ITW Food Equipment Group LLC

P.O. Box 696 ■ Louisville, KY 40201 ■ Toll-free: 1-800-814-2028 ■ Local: 502-778-2791 ■ Quote & Order Fax: 1-800-444-0602

NOTE: In line with its policy to continually improve its products, Vulcan reserves the right to change materials and specifications without notice.

S T E A M

VULCAN**SCALEBLOCKER™
WATER FILTER SYSTEM****Model SMF600****SPECIFICATIONS**

Water filter system, Vulcan Model No. SMF_____. Single quick connect cartridge design. Patented technology reduces lime scale, chlorine, and chloramines without chemicals or additives. Reduces the need of frequent deliming. Modular mounting bracket and head assembly with ¼ turn quick connect cartridge. Shutoff valve and connection for treated water for generator and untreated for cold water condensate. Filter water test port with shut off valve. Incoming water parameters are 40-125 PSI, 45-100°F, PH 6-9, alkalinity 80-100 PPM, chlorine/chloramines 0-4 PPM. chlorides 0-30 PPM, hardness 0-300 PPM (0 to 17.5 grains). Water connections are ¾" NPTM with ¾" Male GHT.

Exterior Dimensions:**SMF600:** 15½"w x 9½"d x 18½"h**SMF620:** 15½"w x 9½"d x 29½"h

NSF tested and certified.

- SMF600** Water Filter System
- SMF620** Water Filter System

STANDARD FEATURES

- Single cartridge design
- ¼ turn cartridge quick disconnect and connect for easy changes, no wrench required
- Category 3 recyclable cartridge
- Nano crystal scale reduction reduces the need for deliming
- Hollow carbon for chlorine/chloramines removal
- Modular mounting bracket and head assembly
- Quick connect inlet and outlet assemblies for reversing flow or adding optional pre-filter.
- Shut off valve and pressure gauge standard
- Connections are ¾-inch NPTF with ¾-inch Male GHT adaptors installed (male garden hose thread)
- Filtered water test valve
- Unfiltered water connection for cold water condensate with cap if not used
- Free filter maintenance reminders when system is registered with Vulcan
- Treats water up to 300 PPM (17.5 grains), hardness
- Removes up to 4 PPM chlorine/chloramines

ACCESSORIES (Packaged & Sold Separately)

- Preventive maintenance kit
- Stainless steel flex water connection hose 72", ⅝" Female GHT, (garden hose thread), each end.
- 14" deliming tank and dip tube for steamers without deliming port
- Case deliming agent, 24 14 oz. bags
- Pre-filter kit for high turbidity water, extends life of scale reduction filter
- Pre-filter cartridge replacement, sediment only
- Pre-filter cartridge replacement, sediment and chlorine/chloramines

VULCAN

a division of ITW Food Equipment Group LLC

P.O. Box 696 ■ Louisville, KY 40201 ■ Toll-free: 1-800-814-2028 ■ Local: 502-778-2791 ■ Quote & Order Fax: 1-800-444-0602

S T E A M

VULCAN**SCALEBLOCKER™
WATER FILTER SYSTEM****NOTES:**

1. Dimensions which locate the below connections have a tolerance of + or - 3" (+ or - 77mm).
2. Installation of backflow preventers, vacuum breakers, other code requirements and local code compliance is the responsibility of the owner and installer.
3. Filter clearance needed for access:
Front 13"
Bottom 4"
4. This appliance is manufactured for commercial installation only and not intended for home use.

SMF600

| | |
|--------------------------|--|
| Service Flow | 0-2 GPM |
| Service Life | 7,500 Gal |
| Inlet / Outlet | ¾" NPTF inlet and ¾" Male GHT (¾" NPTF adapter) outlet |
| Inlet Min / Max Pressure | 40-125 PSIG |
| Min / Max Temperature | 45-100F (7-37C) |
| Weight, Operating | 21 Lbs. (9.5 kg) |

SMF620

| | |
|--------------------------|--|
| Service Flow | 0-4 GPM |
| Service Life | 12,000 Gal |
| Inlet / Outlet | ¾" NPTF inlet and ¾" Male GHT (¾" NPTF adapter) outlet |
| Inlet Min / Max Pressure | 40-125 PSIG |
| Min / Max Temperature | 45-100F (7-37C) |
| Weight, Operating | 32 Lbs. (15.5 kg) |

WATER QUALITY STATEMENT:

Water from ScaleBlocker™ System should only be connected to the boiler / generator feed and not the condenser connection of the steamer. Systems are not to be used where water is microbiologically unsafe or with water of unknown quality without adequate disinfections before and after use. Connecting to a municipal water supply complies with this requirement.

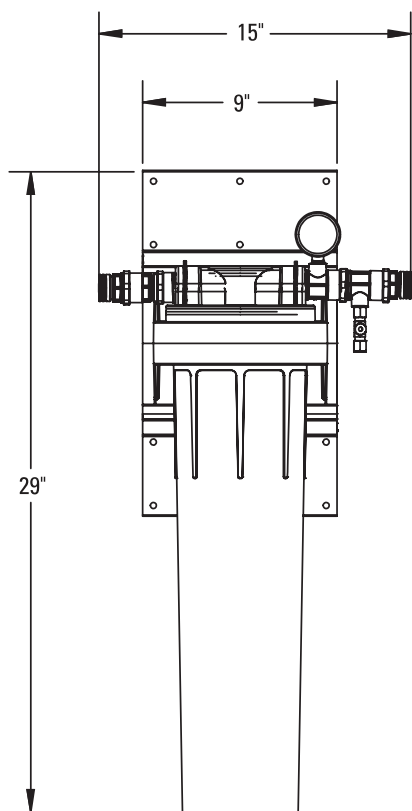
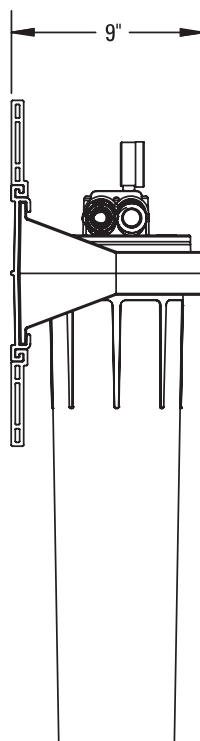
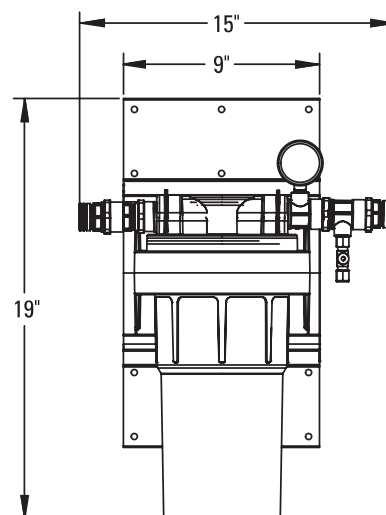
**SMF620-SYSTEM****TYPICAL SIDE VIEW****SMF600-SYSTEM****VULCAN**

a division of ITW Food Equipment Group LLC

P.O. Box 696 ■ Louisville, KY 40201 ■ Toll-free: 1-800-814-2028 ■ Local: 502-778-2791 ■ Quote & Order Fax: 1-800-444-0602

NOTE: In line with its policy to continually improve its products, Vulcan reserves the right to change materials and specifications without notice.

S T E A M

VULCAN**VE SERIES
MODULAR ELECTRIC TILTING BRAISING PAN**

Shown with enclosed faucet bracket

**SPECIFICATIONS**

Modular electric tilting braising pan, Vulcan-Hart Model No. (VE30) (VE40). 36"/46" wide open base. Stainless steel front, sides and 12" legs with adjustable flanged feet. Stainless steel finishing back. Front hinged polished stainless steel pan body with coved interior corners and embossed gallon markings. Stainless steel cooking surface bonded to steel plate. Full width 4" return flange with formed pouring lip and removable strainer. Stainless steel spring assist cover with full width handle. Drop away food pan receiving support mounts under pouring lip. Manually operated pan lifting mechanism with folding swing away handle. Pan can be fully tilted to empty completely with approximately 30 crank revolutions. Flat firebar heating elements affixed to pan bottom for even heat distribution. Elements shut off when pan is tilted 5°. Solid state temperature controls. Water tight controls and enclosures. Shipped for 208/60-50/3 electrical service. Can be field converted to 208/60-50/1 and 240/60-50/3 and 240/60-50/1.

Exterior dimensions: _____"w x 35 1/2"d x 40 1/2"h on 12" legs.

U L listed. U L listed to Canadian safety standards. Classified by U L to NSF Std. #4.

- VE30** 36" wide open base.
 VE40 46" wide open base.

STANDARD FEATURES

- Stainless steel front, sides and 12" legs with adjustable flanged feet.
- Stainless steel finishing back.
- Front hinged polished stainless steel pan body with coved interior corners and embossed gallon markings. Stainless steel cooking surface bonded to steel plate. Full width 4" return flange with formed pouring lip and removable strainer.
- Stainless steel spring assist cover with wrap around handle and condensate lip.
- Stops in place for vented cooking.
- Faucet mounting bracket (non-enclosed) field reversible "L" bracket either side.
- Drop away food receiving pan support mounts under pouring lip.
- Manually operated pan lifting mechanism with folding swing away handle. Pan can be fully tilted to empty completely with approximately 30 crank revolutions.
- Flat firebar heating elements affixed to pan bottom for even heat distribution. Elements shut off when pan is tilted 5°.
- Solid state temperature controls.
- Water tight controls and enclosures.
- Shipped for 208/60-50/3 electrical service. Can be field converted to 208/60-50/1 and 240/60-50/3 and 240/60-50/1.
- One year limited parts and labor warranty.

OPTIONS

- Motor driven pan lift.
- Two inch draw-off valve – left front straight with strainer. (BPDOV-1) Pan support will be removed on VE30.
- Two inch draw-off valve – left front 90° left with strainer. (BPDOV-2) Pan support will be removed on VE30.
- Two inch draw-off valve – left side 90° front with strainer. (BPDOV-3)
- Standard prison package includes:
 - Security screws and tackwelds.
 - Includes securing crank handle, pan strainer and non-door type panels.
 - Controls protected by lockable cover.
 - Perforated lid support cover.
- 480 volt, 60-50 Hz, 3 phase.
- Second year extended limited parts and labor warranty.

ACCESSORIES (Packaged & Sold Separately)

- Set of four casters, (four locking).
- Faucet bracket assembly (adds 3" to width).
- (12") (18") double jointed single pantry faucet.
- (12") (18") double jointed double pantry faucet.
- Double pantry washdown hose with 16" add-on faucet with backflow preventer.
- Double pantry washdown hose with backflow preventer.
- Double pantry pot filler and backflow preventer.
- Steaming pan insert rack to hold 12" x 20" pans. (Qty. _____)
- 12" x 20" x 4" stainless steel drain waste pan with clear plastic hose.
- Catch can with bail handle and drain hose for draw-off valve.
- Stainless steel perforated boiling basket (12" x 20" x 6" deep) with handles.

VULCAN

a division of ITW Food Equipment Group LLC

P.O. Box 696 ■ Louisville, KY 40201 ■ Toll-free: 1-800-814-2028 ■ Local: 502-778-2791 ■ Quote & Order Fax: 1-800-444-0602

STEAM



VE SERIES
MODULAR ELECTRIC TILTING BRAISING PAN

SERVICE CONNECTIONS:



ELECTRICAL CONNECTION: Heating element, control and motor power 1³/₈" dia. (1" conduit). See capacity schedule.

| MODEL | COOKING SURFACE AREA | CAPACITY | 4 OZ. PORTIONS |
|-------|----------------------|--------------------|----------------|
| VE30 | 29" x 23" | 30 gal./114 liters | 960 |
| VE40 | 39" x 23" | 40 gal./152 liters | 1280 |

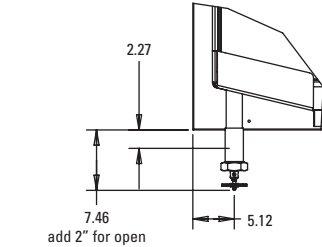
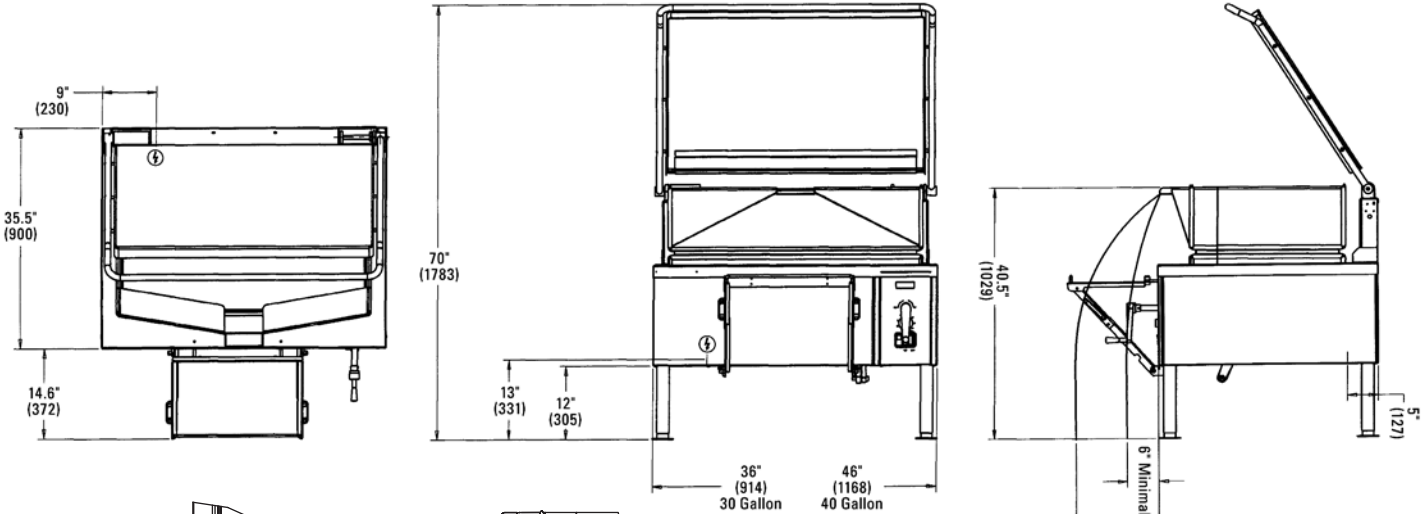

2" Draw-off valve – left front straight (BPD0V-1)

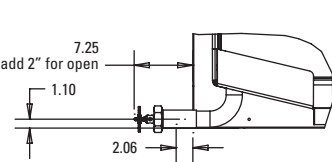

2" Draw-off valve – left front 90° left (BPD0V-2)

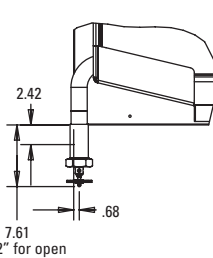

2" Draw-off valve – left side 90° front (BPD0V-3)

| MODEL VE30 ELECTRICAL | | | | | | | | | |
|-----------------------|-----|-----|-----|-----|-----------|-----|-----|-----|-----|
| THREE PHASE | | | | | ONE PHASE | | | | |
| 208 | | 240 | | 480 | | 208 | | 240 | |
| KW | AMP | KW | AMP | KW | AMP | KW | AMP | KW | AMP |
| 9 | 25 | 12 | 29 | 12 | 15 | 9 | 43 | 12 | 50 |

| MODEL VE40 ELECTRICAL | | | | |
|-----------------------|----|---------|---------|---------|
| VOLTAGE/PHASE | KW | AMPS L1 | AMPS L2 | AMPS L3 |
| 208 / 1 | 12 | 58 | 58 | - |
| 240 / 1 | 16 | 67 | 67 | - |
| 208 / 3 | 12 | 39 | 39 | 25 |
| 240 / 3 | 16 | 46 | 46 | 29 |
| 480 / 3 | 16 | 23 | 23 | 15 |



a division of ITW Food Equipment Group LLC

P.O. Box 696 ■ Louisville, KY 40201 ■ Toll-free: 1-800-814-2028 ■ Local: 502-778-2791 ■ Quote & Order Fax: 1-800-444-0602

NOTE: In line with its policy to continually improve its products, Vulcan reserves the right to change materials and specifications without notice.

HEATED HOLDING**VULCAN****VPT SERIES
PASS THROUGH HOLDING CABINETS**

Model VPT15



UL Listed. UL Listed to Canadian safety standards.
Classified by UL to NSF Std. #4.

SPECIFICATIONS

Vulcan Model No. VPT pass through holding cabinets. Blower motor for gentle and even temperature distribution. Complete with 5" heavy duty casters (2 swivel with brakes and 2 rigid). Simple knob actuated electronic control for holding at temperatures up to 190°F. Adjustable racking will hold 18" x 26" or 12" x 20" pans or a combination of both on 1½" centers. Lip-load racking will hold 18" x 26" pans on 3" centers. Shelving will hold a variety of pan sizes. Cabinet interior and exterior are both constructed out of 20 gauge stainless steel. Recessed side-mounted handles, magnetic action door latch, and full insulation; 1½" in side walls and 2" in top. Integrated stainless steel frame for maximum strength. Field reversible doors. Complete with side mounted cord and plug; NEMA 5-15 for 120 volts and NEMA 6-15 for 208-240 volts. One year limited parts and labor warranty. After the first year, lifetime parts warranty on the heating elements. ENERGY STAR® qualified.

Units with adjustable racking:

- VPT7** (see reverse for capacities)
- VPT13** (see reverse for capacities)
- VPT15** (see reverse for capacities)
- VPT18** (see reverse for capacities)

Units with lip-load racking:

- VPT7LL** (Fifteen 18" x 26" x 1" sheet pans)
- VPT15LL** (Thirty 18" x 26" x 1" sheet pans)

Units with shelves:

- VPT7SL** (Three Shelves)
- VPT15SL** (Six Shelves)

STANDARD FEATURES

- Pass-Thru Holding Capacity:
 - 18" x 26" sheet pans.
 - 12" x 20" pans, or a combination of both on 1½" centers.
 - Other pan sizes on shelves.
- Blower motor for gentle and even temperature distribution.
- Dutch doors (VPT15 and VPT18).
- 5" heavy duty casters (2 swivel with brakes and 2 rigid).
- Recessed side mounted handles.
- Simple knob actuated electronic control for holding at temperatures up to 190°F.
- Universal tray slides adjustable on 1½" centers. VPT15 & VPT13 ship with 10 pairs of tray slides, VPT7 ships with 5 pairs and VPT18 ships with 15 pairs.
- Interior and the exterior are both constructed out of 20 gauge stainless steel.
- Fully insulated with 1½" in side walls and 2" in top.
- Integrated stainless steel frame for maximum strength.
- Magnetic action door latch.
- Field reversible doors.
- Side mounted cord.
- Complete with cord and plug: NEMA 5-15 for 120 volts and NEMA 6-15 for 208-240 volts.
- One year limited parts and labor warranty. After the first year, lifetime parts warranty on the heating elements.
- ENERGY STAR® qualified.

OPTIONS

- 208/240 volt
- Humidity pan
- Full perimeter bumper
- Glass Dutch doors (VPT15 & VPT7 only)
- Wire shelves to sit on tray slides (RACK-VCH)
- Additional tray slides

VULCAN

a division of ITW Food Equipment Group LLC

P.O. Box 696 ■ Louisville, KY 40201 ■ Toll-free: 1-800-814-2028 ■ Local: 502-778-2791 ■ Quote & Order Fax: 1-800-444-0602

HEATED HOLDING



VPT SERIES
PASS THROUGH HOLDING CABINETS

Drawings shown with optional bumper

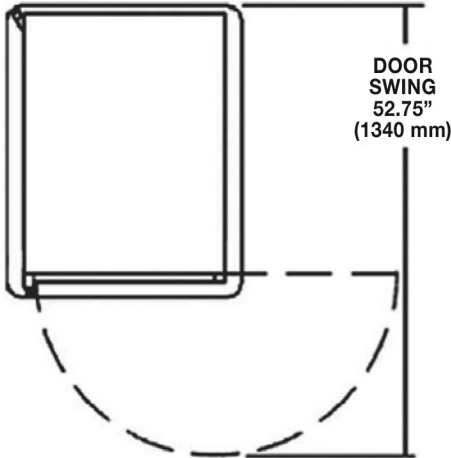

All Models Top View

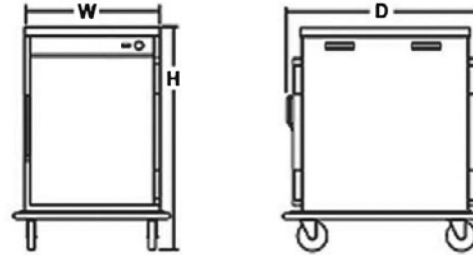

VPT7 Front & Side Views

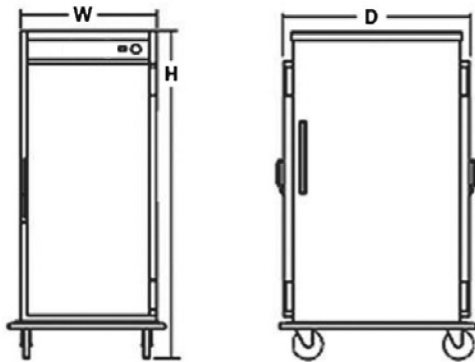

VPT13 Front & Side Views

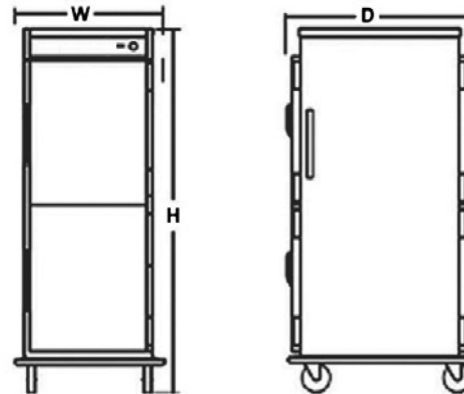

VPT15 Front & Side Views

| MODEL | DIMENSIONS | CAPACITY | | ELECTRICAL | | | SHIPPING WEIGHTS | |
|---------|-------------------------------|---------------------------|----------------------|------------|-------|------|------------------|-----|
| | EXTERIOR | 12" x 20" x 2 1/2" PANS | 18" x 26" SHEET PANS | VOLTS | WATTS | AMPS | LBS | KG |
| VPT7 | 27" W x 34 1/2" D x 40" H | 14 | 7 | 120/240 | 1,500 | 12.5 | 198 | 90 |
| VPT7LL | 27" W x 34 1/2" D x 40" H | NA | 15 | 120/240 | 1,500 | 12.5 | 198 | 90 |
| VPT7SL | 27" W x 34 1/2" D x 40" H | Unit comes with 3 shelves | | 120/240 | 1,500 | 12.5 | 198 | 90 |
| VPT13 | 27" W x 34 1/2" D x 61" H | 26 | 13 | 120/240 | 1,500 | 12.5 | 270 | 123 |
| VPT15 | 27" W x 34 1/2" D x 66 1/2" H | 30 | 15 | 120/240 | 1,500 | 12.5 | 297 | 135 |
| VPT15LL | 27" W x 34 1/2" D x 66 1/2" H | NA | 30 | 120/240 | 1,500 | 12.5 | 297 | 135 |
| VPT15SL | 27" W x 34 1/2" D x 66 1/2" H | Unit comes with 6 shelves | | 120/240 | 1,500 | 12.5 | 297 | 135 |
| VPT18 | 27" W x 34 1/2" D x 73 1/2" H | 36 | 18 | 120/240 | 1,500 | 12.5 | 337 | 153 |

*per compartment

Optional bumper adds 3/4" to the width and 1 5/8" to the depth.



a division of ITW Food Equipment Group LLC

P.O. Box 696 ■ Louisville, KY 40201 ■ Toll-free: 1-800-814-2028 ■ Local: 502-778-2791 ■ Quote & Order Fax: 1-800-444-0602

NOTE: In line with its policy to continually improve its products, Vulcan reserves the right to change materials and specifications without notice.

HEATED HOLDING**VULCAN****VP18
18 PAN NON-INSULATED
HEATED HOLDING & PROOFING CABINET**

Model VP18

**STANDARD FEATURES**

- Eighteen level heated holding and proofing cabinet accepts eighteen 18" x 26" pans or thirty-six 12" x 20" pans.
- Heavy duty 20 gauge polished stainless steel cabinet.
- Set of 5" casters, two swivel with brakes and two rigid.
- Full size glass door with field reversible heavy duty hinges, door latch mechanism, and gaskets provide visibility of the contents in the cabinet.
- Adjustable interior pan supports adjust on 3" centers and are removable for easy cleaning.
- Top mounted, recessed control panel includes fan on/off switch, dial thermostat adjustable from ambient to 190°F, cabinet temperature thermometer, and switch to change from proofing to holding.
- Top mounted control panel is easy to use and out of the way of brooms, mops, and feet. Control panel on top eliminates removing control panel for cleaning.
- Fan and air tunnel provide even heat distribution.
- 2,000 total watt heating elements with stainless steel cover, 16.7 amps total draw.
- Requires 120 volt, single phase power supply.
- Furnished with top mounted power cord with strain relief and NEMA 5-20 plug (except for Canada which comes with a 5-30 plug).
- Furnished with ten pairs of tray slides.
- Includes 1/2 gallon water pan for proofing, drip trough and removable condensation pan on the bottom of cabinet.
- One year limited parts and labor warranty. After the first year, lifetime parts warranty on the heating elements.

SPECIFICATIONS

Eighteen level heated holding and proofing cabinet, Vulcan Hart Model No. VP18. Heavy duty 20 gauge polished stainless steel cabinet. Four 5" casters, two swivel with brakes, two rigid. Glass door with heavy duty hinges, door latch mechanism and gaskets. Adjustable interior pan supports adjust on 3" centers and are removable for easy cleaning. Accommodates up to eighteen 18" x 26" sheet pans and thirty six 12" x 20" x 2 3/4" steam table pans. Includes 1/2 gallon water pan for proofing, drip trough and removable condensation pan on the bottom of cabinet. Top mounted, recessed control panel includes fan on/off switch, dial thermostat adjustable from ambient to 190°F, cabinet temperature thermometer, and switch to change from proofing to holding. 2,000 total watt heating elements with stainless steel cover, 16.7 total amp draw. One year limited parts and labor warranty. After the first year, lifetime parts warranty on the heating elements. Requires 120 volt single phase power supply. Furnished with top mounted power cord with strain relief and NEMA 5-20 plug.

Exterior Dimensions:

25 1/4" W x 30 3/4" D x 71" H

UL Listed. Classified by UL to NSF Std. #4.

VULCAN

a division of ITW Food Equipment Group LLC

P.O. Box 696 ■ Louisville, KY 40201 ■ Toll-free: 1-800-814-2028 ■ Local: 502-778-2791 ■ Quote & Order Fax: 1-800-444-0602

HEATED HOLDING



VP18
18 PAN NON-INSULATED
HEATED HOLDING & PROOFING CABINET

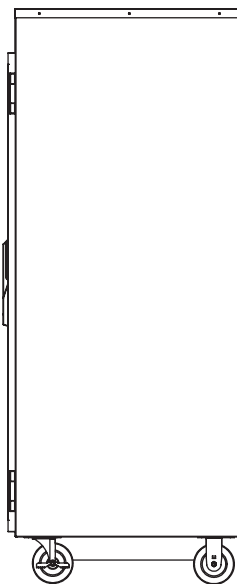
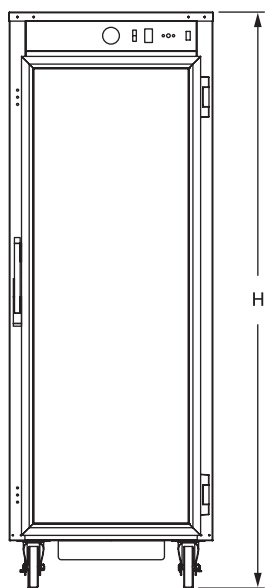
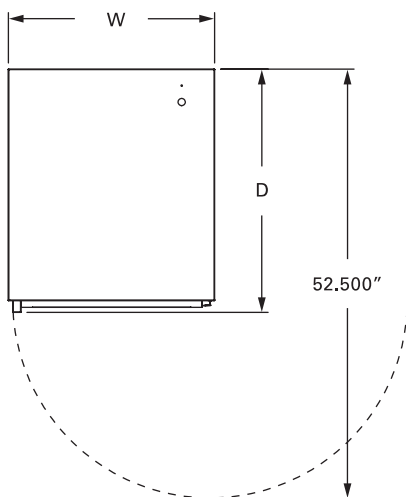

| CAPACITY | | DIMENSIONS | ELECTRICAL | | | SHIPPING WEIGHTS |
|----------------|----------------|-------------------------------|------------|-------|------|--------------------|
| 18" X 26" PANS | 12" X 20" PANS | | VOLTS | WATTS | AMPS | LBS / KG |
| 18 | 36 | 25 1/4" W x 30 3/4" D x 71" H | 120 | 2,000 | 16.7 | 236 lbs. / 107 kg. |



a division of ITW Food Equipment Group LLC

P.O. Box 696 ■ Louisville, KY 40201 ■ Toll-free: 1-800-814-2028 ■ Local: 502-778-2791 ■ Quote & Order Fax: 1-800-444-0602

NOTE: In line with its policy to continually improve its products, Vulcan reserves the right to change materials and specifications without notice.